

For more information contact...

WOODFORD MANUFACTURING COMPANY, LLC

2121 Waynoka Road, Colorado Springs, Colorado 80915 • Phone: (800) 621-6032

To view our complete product line visit: www.woodfordmfg.com or email: sales@woodfordmfg.com

Rev 06/23 Form No. TMUtilityM.104

Utility Yard Hydrant Lever Handle Models

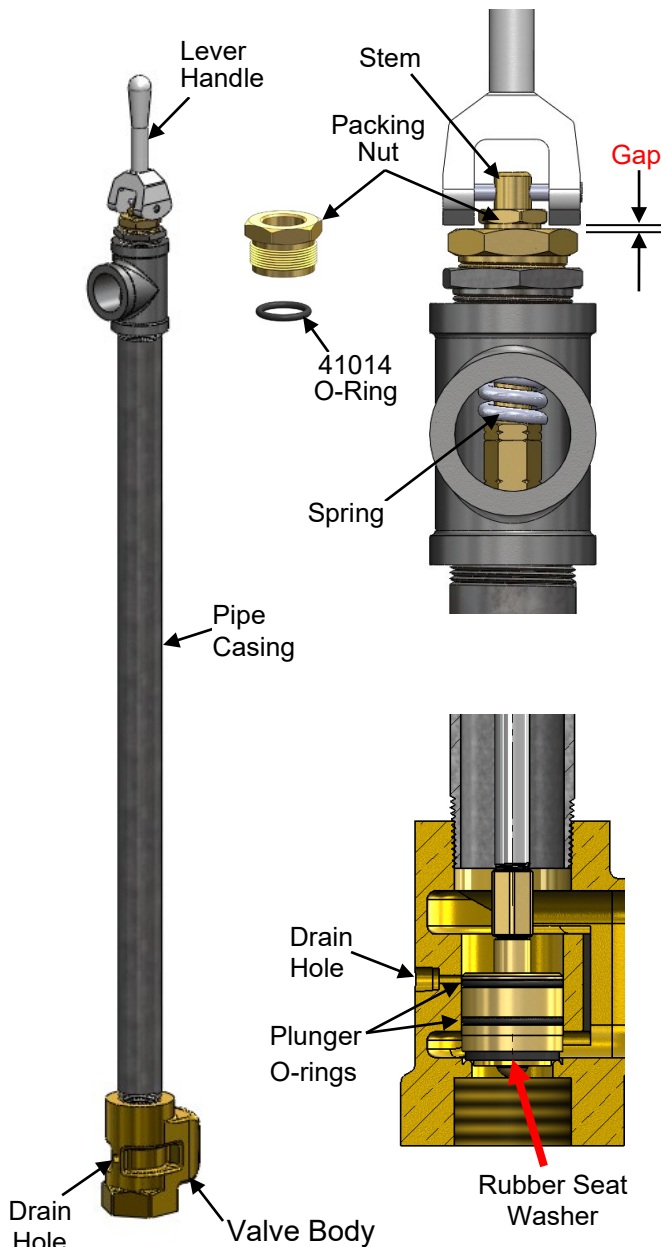

Water leaks from the outlet when the hydrant is off.

- Lever handle hydrants require a 1/16" – 1/8" **Gap** between the handle and surface the handle rides. If there is no gap and the handle does not have any play, it can leak. Tighten nut under handle to achieve a gap.
- Lever handle hydrants use a spring tension to seat the rubber. Excessive supply pressure can cause the hydrant to leak.
- The rubber Valve Seat Washer may be worn or damaged and needs to be replaced. See [Operating Pipe Removal](#) instructions.
- If the hydrant leaks just after installation, the valve seat may be fouled with debris, such as small rocks. The operating pipe assembly will have to be removed and the hydrant casing flushed. See [Operating Pipe Removal](#) instructions.

Packing leak: Water leaks around the brass stem below the linkage when the hydrant is on.

- Utility hydrants use an O-ring to seal the Stem. First make sure the Packing Nut is tight. If the leak continues, the O-ring needs to be replaced. [Order 41014 O-Ring](#)

Hydrant leaks from below ground level when the hydrant is on.

- If the hydrant leaks when full on, the Plunger O-Rings may be damaged and need to be replaced. See [Operating Pipe Removal](#) instructions.
- A large leak may be the result of a hole in the pipe casing caused by electrolysis corrosion. Some soil conditions can cause premature failure of the pipe casing near the valve body.

Hydrant will not drain when shut off.

- Make sure there are no attachments on the outlet, such as a hose or vacuum breaker.
- A poor drain field around the valve body or a blocked

For more information contact...

WOODFORD MANUFACTURING COMPANY, LLC

2121 Waynoka Road, Colorado Springs, Colorado 80915 • Phone: (800) 621-6032

To view our complete product line visit: www.woodfordmfg.com or email: sales@woodfordmfg.com

Rev 06/23 Form No. TMUtilityM.104

Utility Yard Hydrant Operating Pipe Removal (Lever Handle Models)

Fig 1

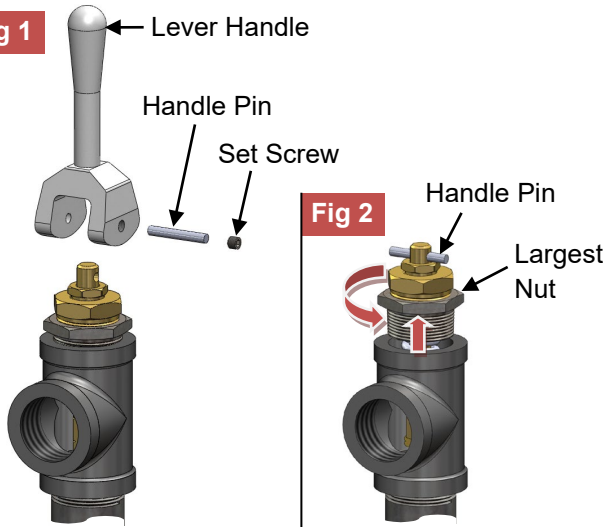
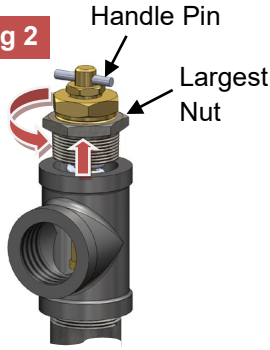

Fig 2



1. Shut off water supply to hydrant.
2. Remove the Set Screw from the side of the Handle and pull the Handle Pin. **Fig 1**
3. Place the Handle Pin back through the hole in the Stem. The Handle Pin in the Stem will keep the Spring from losing its compression and keep the assembly together. **Fig 2**
4. Unthread the largest Nut from the Tee or casting. **Fig 2**
5. Pry the Rod Assembly loose from the Valve Seat and remove the entire Rod Assembly. **Fig 3**
6. Inspect Plunger Rubber, O-rings and Seals for damage. *Plunger Assemblies are available for all Utility Hydrant models.*

Fig 3



Plunger Assemblies 8 Parts		
Plunger Assembly #	Fits Hydrant Model	Plunger Dia.
41060	U100A/M & U125A/M	1"
41078	U150A/M	1-1/2"
41089	U200A/M	1-13/16"

Plunger Assembly 7 Parts	
Plunger Assembly #	Fits Hydrant Model
41018	U34A/M & U75A/M

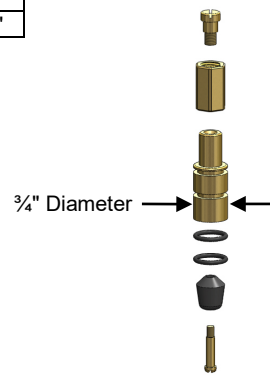
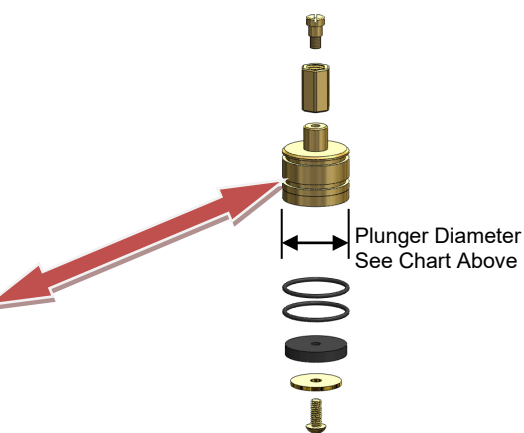

For more information contact...

WOODFORD MANUFACTURING COMPANY, LLC

2121 Waynoka Road, Colorado Springs, Colorado 80915 • Phone: (800) 621-6032

To view our complete product line visit: www.woodfordmfg.com or email: sales@woodfordmfg.com

Rev 06/23 Form No. TMUtilityM.104

Utility Yard Hydrant Wheel Handle Models

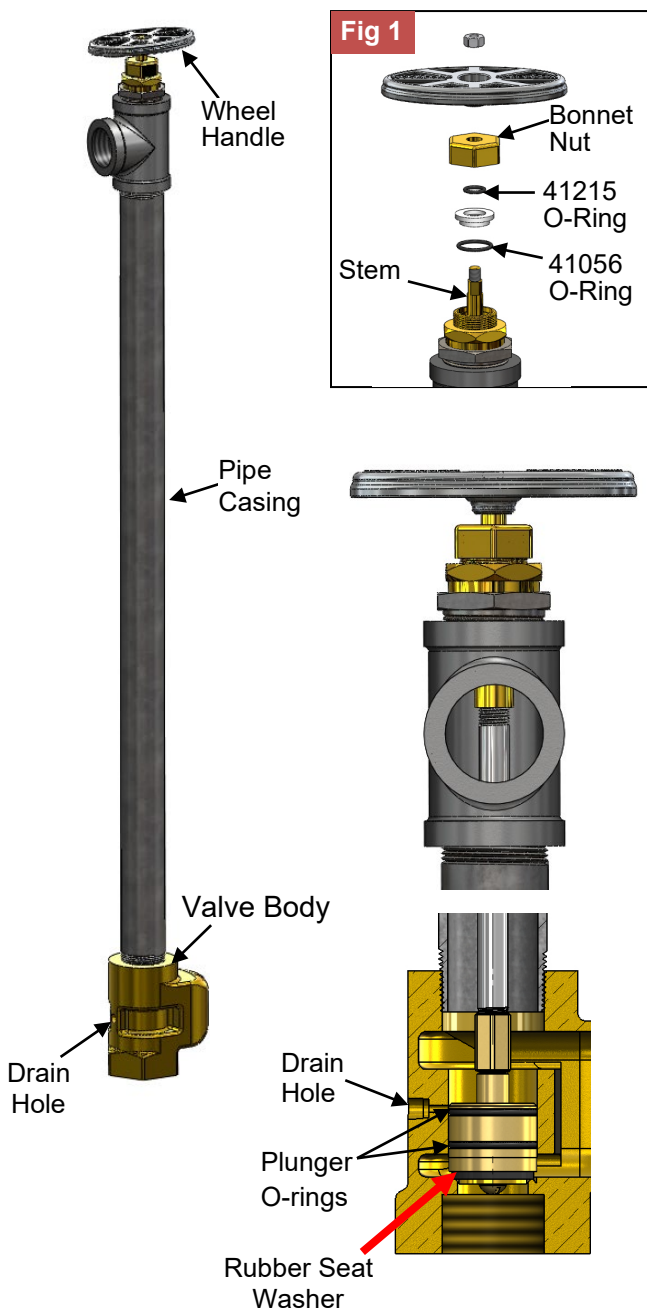

Water leaks from the outlet when the hydrant is off.

- The rubber Valve Seat Washer may be worn or damaged and needs to be replaced. See [Operating Pipe Removal](#) instructions.
- If the hydrant leaks just after installation, the valve seat may be fouled with debris, such as small rocks. The operating pipe assembly will have to be removed and the hydrant casing flushed. See [Operating Pipe Removal](#) instructions.

Packing leak: Water leaks around the brass stem below the linkage when the hydrant is on.

- Utility hydrants use an O-Ring to seal the Stem. First make sure the Bonnet Nut is tight. If the leak continues, the O-Ring needs to be replaced. [Order 41215 O-Ring Fig 1](#)

Hydrant leaks from below ground level when the hydrant is on.

- Wheel handle hydrants must be open more than half way or else they will leak from the drain during use.
- If the hydrant leaks when full on, the Plunger O-Rings may be damaged and need to be replaced. See [Operating Pipe Removal](#) instructions.
- A large leak may be the result of a hole in the pipe casing caused by electrolysis corrosion. Some soil conditions can cause premature failure of the pipe casing near the valve body.

Hydrant will not drain when shut off.

- Make sure there are no attachments on the outlet, such as a hose or vacuum breaker.
- Make sure the hydrant is shut off completely.
- A poor drain field around the valve body or a blocked drain hole will also prevent drainage. See [Yard Hydrant Installation Instructions](#).

For more information contact...

WOODFORD MANUFACTURING COMPANY, LLC

2121 Waynoka Road, Colorado Springs, Colorado 80915 • Phone: (800) 621-6032

To view our complete product line visit: www.woodfordmfg.com or email: sales@woodfordmfg.com

Rev 06/23 Form No. TMUtilityM.104

Utility Yard Hydrant

Operating Pipe Removal (Wheel Handle Models)

Fig 1



Fig 2

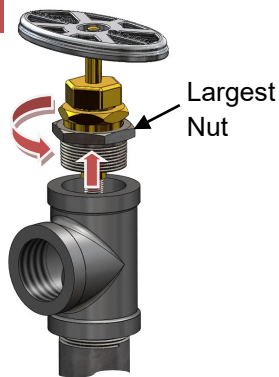

Largest Nut

1. Shut off water supply to hydrant.
2. Turn Handle to full open position. **Fig 1**
3. Unthread the largest Nut from the Tee or casting. **Fig 2**
4. Pry the Rod Assembly loose from the Valve Seat and remove the entire Rod Assembly. **Fig 2 & 3**
5. Inspect Plunger Rubber, O-rings and Seals for damage. *Plunger Assemblies are available for all Utility Hydrant models.*

Fig 3

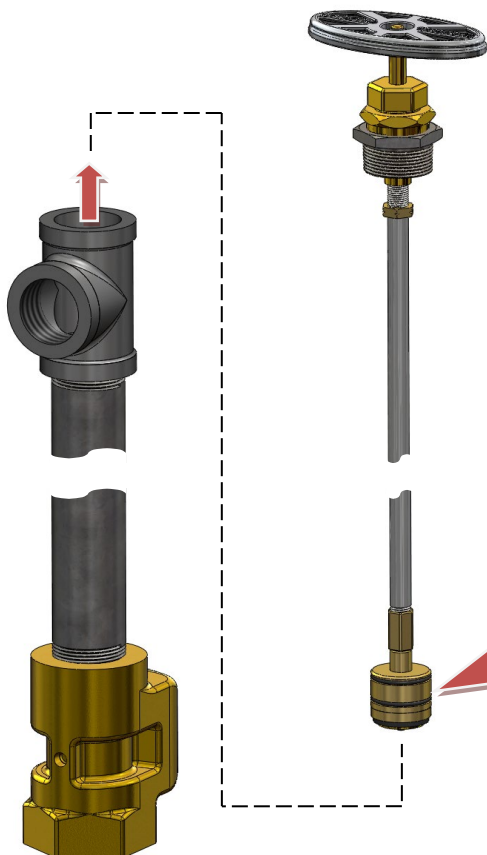

Plunger Assemblies (8 Parts)		
Plunger Assembly #	Fits Hydrant Model	Plunger Dia.
41060	U100W & U125W	1"
41078	U150W	1-1/2"
41089	U200W	1-13/16"

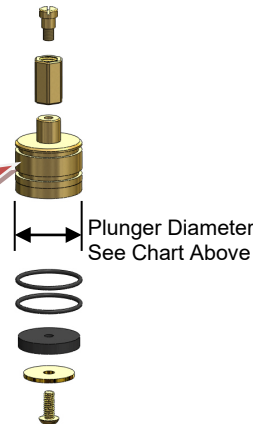

Plunger Diameter
See Chart Above